

Features:

- Three arms for smooth and stable movement so you can see the TV from any angle
- Wall plate cover hides the screws for a clean modern finish
- Built-in spirit level for faster and more accurate installation
- NEO cushioned pads protect the TV from scratches and improve audio insulation
- Save space in your room and keep the TV away from children and pets
- Confidently mount your screen with a high 40kg maximum weight limit
- Suits 32" - 70" TVs, compatible with 200x100 - 400x400 VESA sizes
- Includes fixings for solid walls, stud walls and the TV, for convenience
- High quality steel construction with independent testing by SGS
- Reassurance of a 5 year warranty as standard

Get total control of your TV's position for a great view of the action. Move your screen around or place it in a corner or media wall. Rotates left and right (-/+90°) and tilts up and down (-5/+15°) to get the perfect viewing angle and reduced glare. The TV can extend out for easy access to cables, then pushes back neatly against the wall. Once installed, the position and angles can be changed without tools. Features a wall plate cover to hide the screws, clips for tidy cable management, a built-in spirit level and three shaped metal arms for strength. Easy hook-on installation: lift the TV onto the wall mount and secure with the pull-cord locks. NEO cushioned pads protect the TV from scratches and provide insulation for improved audio. Compatible with VESA sizes 200x100 - 400x400mm.

Technical Specifications:

Max Load	Distance from wall (Folded)	Distance from wall (Extended)	Swivel Range	Tilt Range	No of Articulation Points	Mounting Pattern	VESA Compatible
40Kg/ 88lbs	76mm/ 3.0"	428mm/ 16.9"	±90°	-5°/+15°	4	Single Stud & Solid Wall	200x100 to 400x400



Packed image



Line drawing

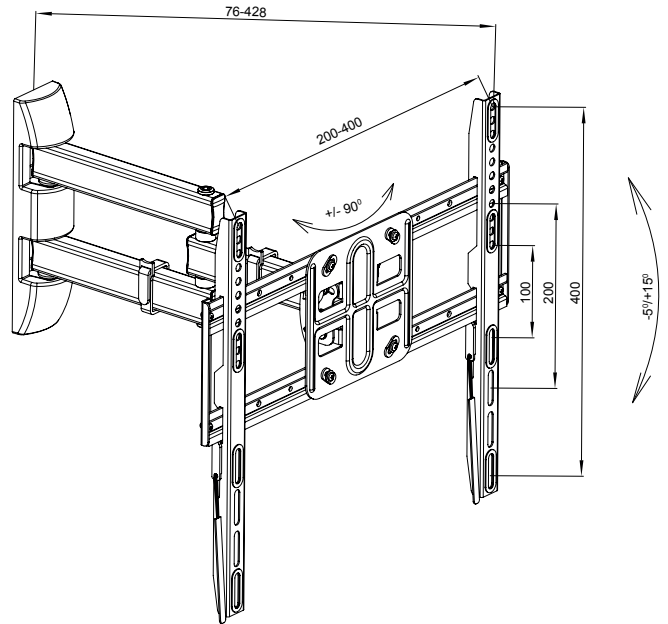

All dimensions are in mm

Packaging Information:

Product Number	Description	Product Packaging		Outer Packaging		
		Type	Barcode	Type	Qty in Box	Barcode
LN2RTA400-RO	Triple Arm Full Motion TV Wall Mount	Colour Gift Box	5015056591810	Brown Outer with Label	2	05015056544410

Weight & Dimensions:

Product			Product Box			Outer Box		
Extended	Folded	Net Weight	Dimensions	Gross Weight	Cubic	Dimensions	Gross Weight	Cubic
43 x 47.4 x 42.8 cm	43 x 47.4 x 7.6 cm	3.53kg	27.3 x 50.9 x 8.2 cm	4.02kg	0.0114m ³	18.4 x 30 x 52 cm	8.48kg	0.0287m ³
16.93" x 18.66" x 16.85"	16.93" x 18.66" x 2.99"	7.78lbs	10.75" x 20.04" x 3.23"	8.86lbs	0.4024ft ³	7.24" x 11.81" x 20.47"	18.7lbs	1.0137ft ³